

TWIN DECKER (SPD)

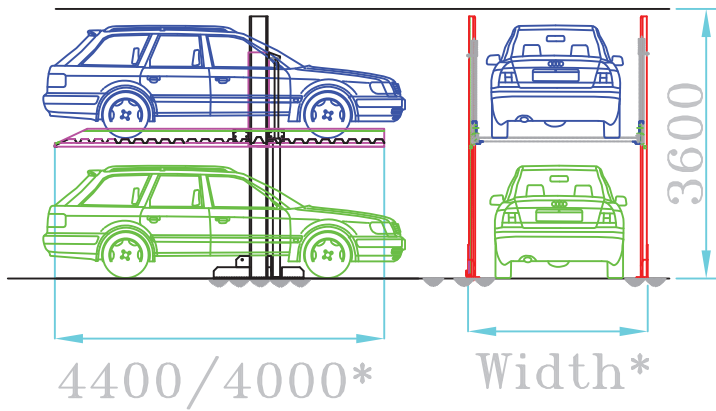

* Can be customised to suit site conditions

Key Advantages

- Low investment & maintenance costs.
- Simple to install & operate.
- Suitable for large parking lots.

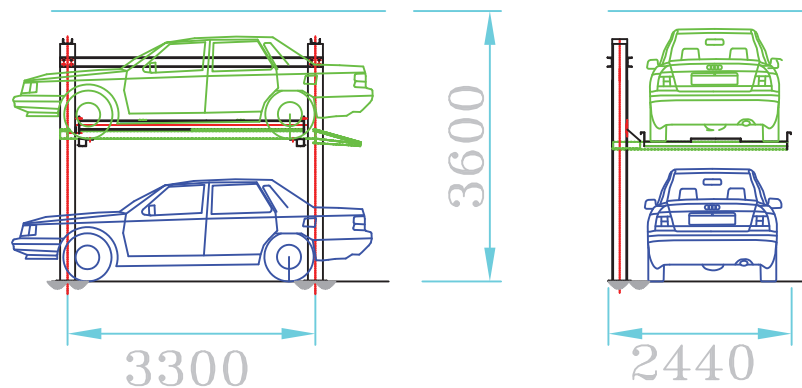

CANTILEVER SYSTEM (SPC)

Specifications[^]

	Twin Decker (Hydraulic)	Cantilever (Mechanical)
Allowable Car Dimension (Length, Width, Height, Weight)	L 5200 x W 1900 x H 1650 mm , 2000 Kg	L 5050 x W 1750 x H 1650 mm, 1600 Kg
Driving Speed	2 M/Min	2 M/Min
Power Pack /Motor	Hydraulic Tank: 20 Ltr. Or more. 2hp/3hp Pump.	2.2 kW x 4p Motor with Gearbox.
Operation	Hydraulic Cylinder & Chain	Motor, Rope & Chain
Operator Interface	Push button / Key Switch	Push Button / Key Switch
Safety	Mechanical safety hook (Standard) Lower Car Sensor (Optional)	Mechanical safety hook (Standard) Lower Car Sensor (Optional)

[^]All specifications are indicative. We reserve right to change the specifications without prior notice.